

SPECIFICATIONS

		N9	N70	N7
Distance Measurement				
EDM System		Laser Class 3R ^①		
		Wave length: 650 - 690 nm. 150MHz Frequency		
Measurement Range	Single Prism ^②	3500m	5000m	5000m
	Reflective Sheet ^③	1000m	2000m	1000m
	Reflectorless ^④	1000m	2000m	1000m
Accuracy	Single Prism	$\pm(1+1\text{ppm}\times D)\text{mm}$		$\pm(2+2\text{ppm}\times D)\text{mm}$
	Reflective Sheet	$\pm(3+2\text{ppm}\times D)\text{mm}$		
	Reflectorless	$\pm(3+2\text{ppm}\times D)\text{mm}$ ^⑤		
Measuring Time	Prism	Tracking<0.1s, Fine<0.3s		
	Sheet	<0.3s		
	Reflectorless	0.3-3s ^⑥		
Atmospheric Correction		Manual Input, Auto Correction		
Prism Constant		Manual Input		
Dist. Unit		Freecale Sensor		
Reading				
Measuring Time		Fine Mode<0.3s; Tracking Mode<0.1s		
Atmospheric Correction		Auto Correction		
Prism Constant		Manual Input		
Angle Measurement				
Measurement Method		Absolute Encoding		
Diameter of Absolute Encoding Disk		79mm		
Minimum Reading		0.1" or 1" option		
Accuracy		1"	2"	2"
Detection Method		Horizontal: 4 path, Vertical: 4 path		
Telescope				
Image		Erect		
Effective Aperture		48mm		
Magnification		30 X		
Field of View		1° 30'		
Minimum Focusing Distance		1.4m		
Automatic Compensator				
System		Dual-Axis Liquid-electric Sensor Compensation		
Working Range		$\pm 4'$		
Accuracy		1"		
Sensitivity of Vial				
Plate Vial		30" /2mm		
Circular Vial		8" /2mm		
Laser Plummet (Default)				
Accuracy		$\pm 1.5\text{mm}$ (in 1.5m InsHt)		
Wave Length		630nm - 670nm		
Laser Power		$\leq 0.4\text{mW}$		
Optical Plummet (Option)				
Image		Erect		
Magnification		3 X		
Focusing Range		0.5m - ∞		
Field of View		5°		
General				
Operate System		Windows CE 6.0		
Processor		Intel PXA310 624Mhz		
Memory		128M DDR, 512M NAND Flash		
Display		3.5inches LCD Touch Screen 640*480dpi		
Communication		RS-232, Mini USB, USB OTG, SD card		
		Bluetooth V2.0+EDR, 10m range		
		WIFI 802.11		
Battery		Rechargeable Lithium Battery		
Voltage		7.4V DC		
Operation Time		6 hours		
Environment		-20°C -- +50°C		
IP Standard		IP55		
Dimension and Weight		196×192×360mm, 6.2kg		

STANDARD PACKING LIST

Main unit	1x
Lens cover	1x
Battery holder	1x
Battery LB-01	2x
Tools pouch	1x
Plummet	1x
SD card	1x
Manual	1x
Warranty card	1x
Charger LC-01	1x
Reflective sheet	1x
Carry case	1x
Belt	2x
Mini USB cable	1x

①EN60825-1: 2007 ②Good conditions: No haze, visibility about 40km. Overcast, no scintillation ③Good conditions. With Koda gray card white side (90%) reflective. sheet size 60*60mm. 400m under good conditions with koda gray card grey side (18%). ④With Kodak gray card white side (90%) reflective. Reflectorless range /accuracy may vary according to measuring objects, observation situations and environmental conditions ⑤ Range less than 200m. When 200m to 500m, 5+2ppm and measurement time maximum less than 10 second ⑥Typical, under good conditions. Range less than 500m. It also depend on object surface. Maximum less than 10s

OPTIONAL ACCESSORIES



ATS-2 Wooden Tripod
NLS-15 Prism Pole
TK21T Prism Set

You Local Authorized Dealer

SOUTH
Target your success

N7/N9 Series Total Station



SOUTH
Target your success

SOUTH SURVEYING & MAPPING TECHNOLOGY CO., LTD.

Add: South Geo-information Industrial Park, No. 39 Si Cheng Road, Tian He IBD, Guangzhou 510663, China
Tel: +86-20-23380888 Fax: +86-20-23380800
E-mail: mail@southsurvey.com export@southsurvey.com impexp@southsurvey.com euoffice@southsurvey.com
http://www.southinstrument.com

World's First- Dual Laser EDM

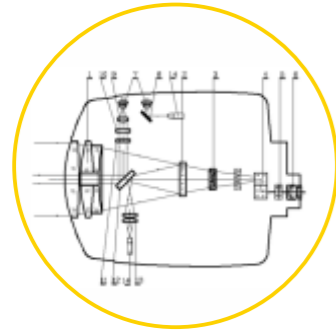
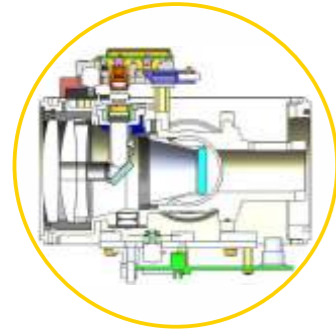

How does dual laser works



Brand new dual laser EDM, it switches in & out light path by electronic laser circuit instead of motor control by mechanical parts.



Combine with updated EDM processor CORTEX M4, dual laser EDM will largely decrease the interval of measurement with stronger return signal.



Through improved noise reduction, weak signal processing is optimized (SNR increased 4 times).



Less light refraction and crosstalk with optimized optical structure.



Better alignment with coaxis mechanical improvement.



Multiple methods for data transfer.

Long-Range EDM



Up to 2000m reflectorless range with quick response in 0.3s. N7/N9 can easily handle the target in tough conditions, eg. roof, wires. also enables N7/N9 to achieve accurate (2+2ppm) measurement in 5.0km with prism.

Smaller Laser Spot



At the distance: 5m, 35m and 50m, N7/N9's laser spot has improved to an accurate size in 3mm, 12mm and 16mm. The smaller laser spot provides a precise guidance for target aiming.

Easy-to-use Onboard System

N7 series total station with fully-open Windows CE 6.0 operate system, featured South EGStar, MGStar, with unique applications.

- Reference Line
- Alignment Setout
- Cross-section Measurement and Stake Out
- Slope Measurement
- Road Design and Stake Out
- COGO, etc.

N7 offers the versatility of third-field software options to choose from, for example Microsurvey's Field Genius, Carlson's SurvCE or any other localized software. It allows you working in your best users experience and run your own developments under standard VGA display unit.

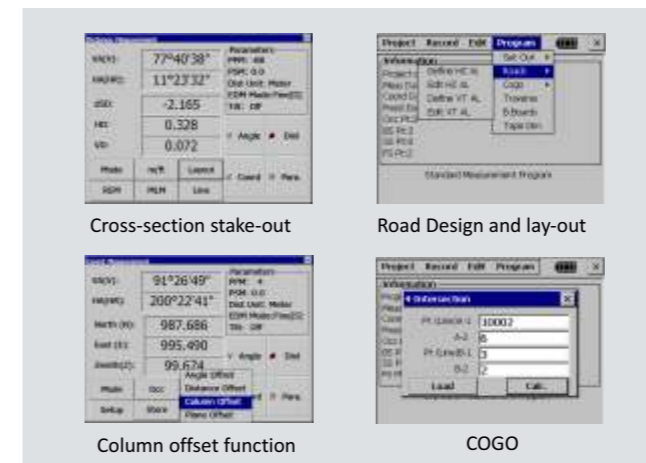

Onboard System

The large graphic display improves the efficiency to access menus and functions by fluent working-flow. N7/N9 afford a complete field-to-office solution to users, includes key features such as COGO Routines, Road Program, Coding, Resection, Stake-out, Reference Line, etc.

Windows CE 6.0 operating system also allows the user run the local software based on different market requirements.

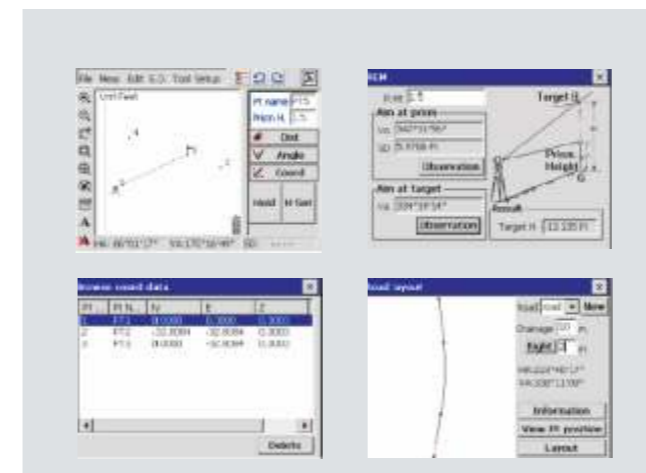

Unique Functions

B-Boards
When stake-out points, particularly for building plots, it is usually necessary to mark a point with an offset.

Tape Dimensions
Tape dim is a program which integrates surveying using a total station and a measuring tape when a quick survey of an object is required.

String Setout
Setting out of points by string (point code) allows the setting out of points on a line created in design software.

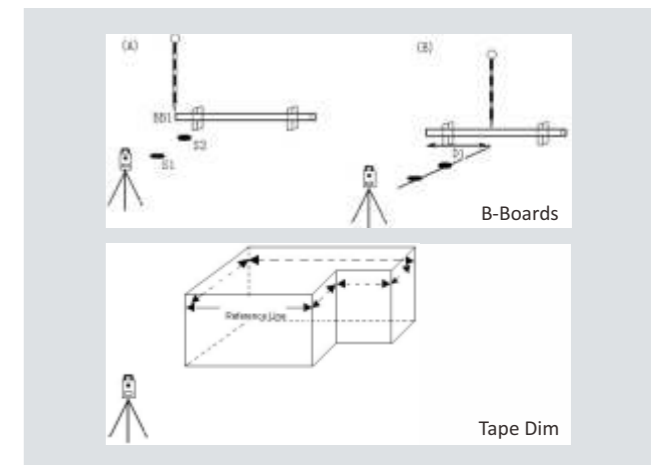

Advanced Applications

N7/N9 series total station with the fully open Windows CE 6.0 operate system, featuring South EGStar, MGStar, Field Genius, SurvCE or any other localized software. It can meet different kinds of request or demands with a highest capability, easier the measurement than normal.

With advanced roading, surfacing, slope staking, smart-points, N7/N9 is the best choice for your daily work.

